

- A1 - IGNITION 3
- A2 - IGNITION 6
- A3 - FIDLE
- A4 - IDLE
- A5 - TACHO
- A6 - NITROUS1
- A7 - TACHO_OUT
- A8 - VREF
- A9 - WBO_GREEN
- A10 - INJECTOR 6
- A11 - INJECTOR 5
- A12 - GNDA
- A13 - INJECTOR3

- B1 - IGNITION 2
- B2 - IGNITION 5
- B3 - LAUNCH_IN
- B4 - FUEL PUMP
- B5 - TABLE SWITCH
- B6 - TPS
- B7 - COOLANT
- B8 - AIR TEMP
- B9 - WBO_BLACK
- B10 - WBO_YELLOW
- B11 - WBO_RED
- B12 - GNDA
- B13 - INJECTOR 2

- C1 - IGNITION 1
- C2 - IGNITION 4
- C3 - WBO_WHITE
- C4 - +12 VOLT
- C5 - GND
- C6 - SENSOR GND
- C7 - WBO_GREY
- C8 - VR1+ (NITROUS2)
- C9 - VR1- / HALL1
- C10 - VR2+ (HALL3)
- C11 - VR2- / HALL2
- C12 - INJECTOR 4
- C13 - INJECTOR 1

RED = With modifications

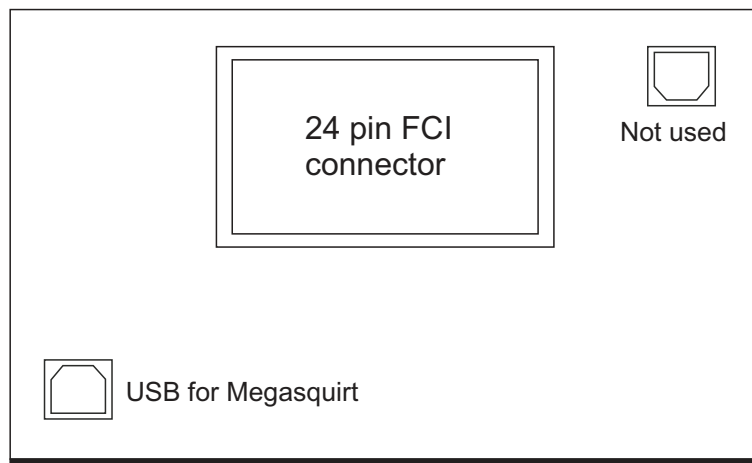
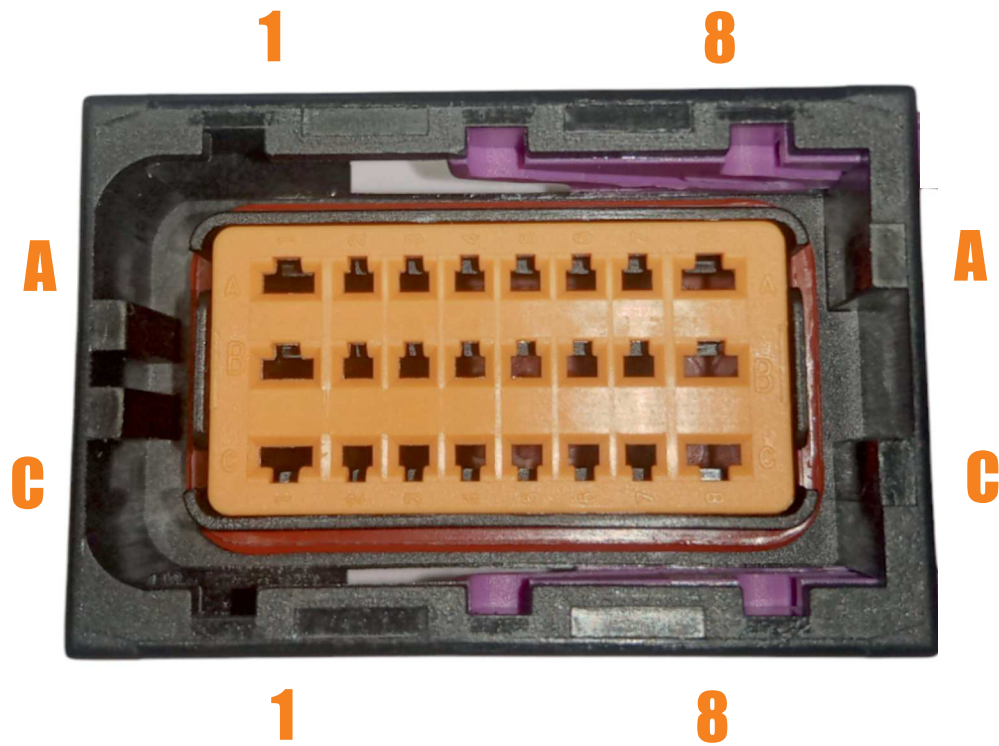

- | | | |
|---------------------|------------------------|----------------------|
| A1 - IGNITION 8 | C1 - INJECTOR 7 / VR3- | B1 - INJECTOR 8/VR3+ |
| A2 - INJ-BANK1 | C2 - STEPPER 2A | B2 - CAN LOW |
| A3 - INJ-BANK2 | C3 - STEPPER 1B | B3 - CAN HIGH |
| A4 - STEPPER 2B | C4 - DATALOG_IN | B4 - KNOCK 2 |
| A5 - STEPPER 1A | C5 - NITRO_IN | B5 - KNOCK 1 |
| A6 - VR4+ / EGT IN+ | C6 - EGO 2 | B6 - VR4- / EGT IN- |
| A7 - SPARE_ADC | C7 - NITROUS 2 | B7 - EXT_MAP |
| A8 - IGNITION 7 | C8 - VVT | B8 - BOOST |

Bosch LSU 4.9 WBO:

+12 VOLT : kapcsolt tápfeszültség
GND: test
GNDA: Nagyáramú test (mindegyiket be kell kötni, min. 1.5mm² kábel!!!)
VREF: referencia feszültség (+5V) szenzorokhoz
SENSOR GND: szenzor test
INJECTOR x : injector kimenet X
IGNITION x : gyújtás kimenet hagyományos vagy logikai trafóhoz (kiépítés függő)
TACHO : 3A-es kapcsolható kimenet
IDLE : 3A-es kapcsolható kimenet
VR1+ : Főtengely VR szenzor +
VR1- / HALL1 : Főtengely VR szenzor - / Hall 1
VR2+ : Veztengely VR szenzor +
VR2- /HALL2 : Veztengely VR szenzor - / Hall 2
VR3+ : 3. VR szenzor + (Opcionális)
VR3- / HALL3 : 3. VR szenzor - / Hall 3 (Opcionális)
VR4+ : 4. VR szenzor + (Opcionális)
VR4- / HALL4 : 4. VR szenzor - / Hall 4 (Opcionális)
LAUNCH IN : rajtprogram gomb
TABLE SWITCH : programváltó kapcsoló bemenet
TACHO OUT : Fordulatszámérő kimenet
FUEL PUMP: benzinpumpa relé kimenet
AIR TEMP : levegőhőmérséglet szenzor
COOLANT : víz hőmérséglet szenzor
TPS : folytószelep-poti bemenet
FIDLE: alapjárat szelep (3A kapcsolható kimenet)
WBO xxxxx : Bosch LSU 4.9 lambda szonda
NITROUS 1: 3A kapcsolható kimenet
NITROUS 2: 3A kapcsolható kimenet
VVT : 5A kapcsolható kimenet
BOOST : 5A kapcsolható kimenet
INJ-BANK 1: 5A kapcsolható kimenet (Opcionális)
INJ-BANK 2: 5A kapcsolható kimenet (Opcionális)
STEPPER X: Stepper alapjárat motor (Opcionális)
SPARE_ADC: Analóg bemenet
EGO 2: Analóg bemenet
EXT_MAP: Analóg bemenet
DATALOG_IN : Digitális bemenet
NITRO_IN : Digitális bemenet
KNOCK 1 ÉS 2: Knock bemenet (Opcionális)



- 1 - RED
- 2 - YELLOW
- 3 - WHITE
- 4 - GREY
- 5 - GREEN
- 6 - BLACK

The injectors and coils need to connect to the ecu in firing order.

Example:

If your firing order is 1-5-3-6-2-4

Ignition1 and Injector1 out to cylinder 1
Ignition2 and Injector2 out to cylinder 5
Ignition3 and Injector3 out to cylinder 3
Ignition4 and Injector4 out to cylinder 6
Ignition5 and Injector5 out to cylinder 2
Ignition6 and Injector6 out to cylinder 4

HALL sensor:

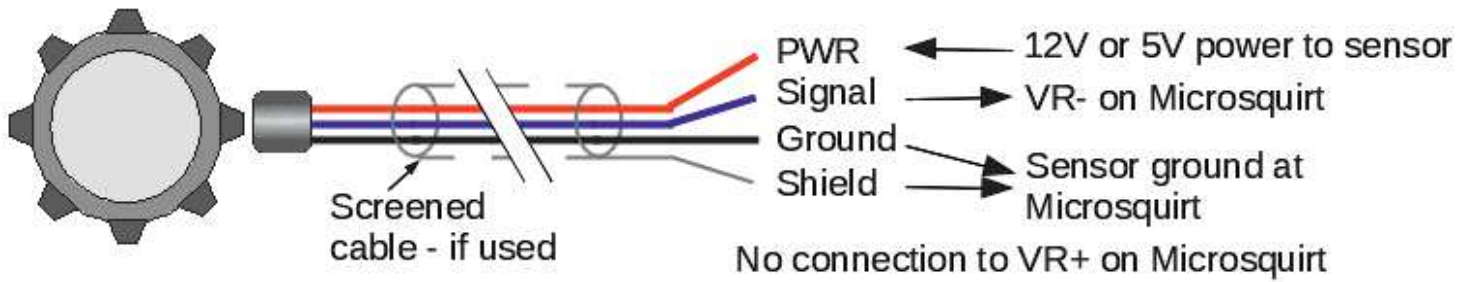

HALL pull-up resistors inside the box

VR sensor:

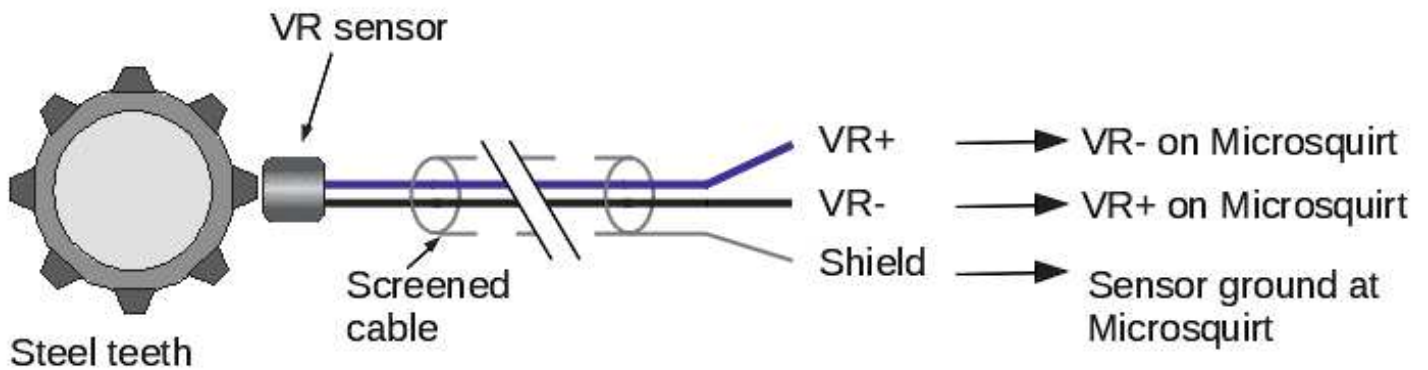

Some installs may find it necessary to install a "shunt" resistor between VR+ and VR- to reduce the signal voltage at higher RPMs. A 1/4W resistor is sufficient and values in the range of 1k to 10k. 10k is recommended for 60-2 wheels.

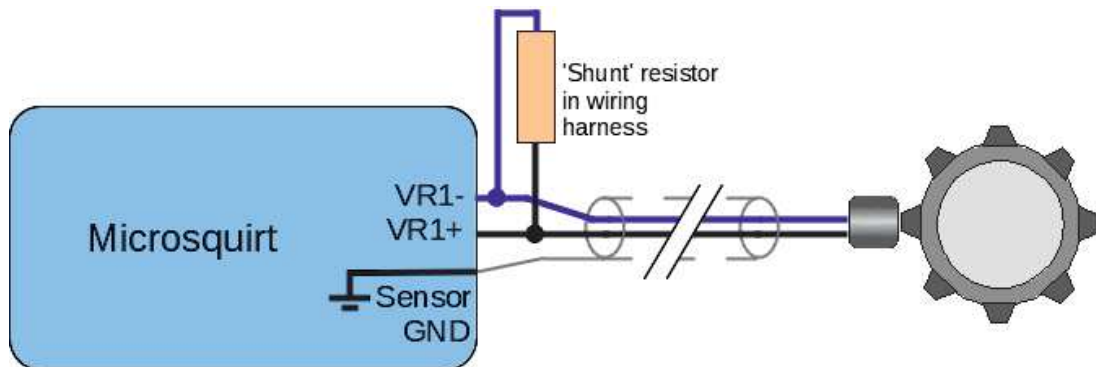

Jumpers inside the FFG_Megasquirt:

VR2 SONT } VR2 Circuit
 VR2 HALL }
 VR1 SONT } VR1 Circuit
 VR1 HALL }

For hall sensor:

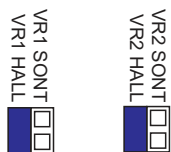

For VR sensor:

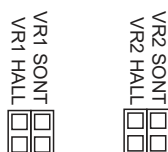

For VR sensor with sont resistor:

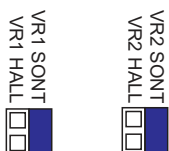

The internal sont resistor is 2,2kohm

